

Bachelor of Science in Business Administration

HUMAN RESOURCE MANAGEMENT

All Business-related courses above 299 require a C- in HMXP 102/HXCT 301, Junior Status, and a 2.0 GPA

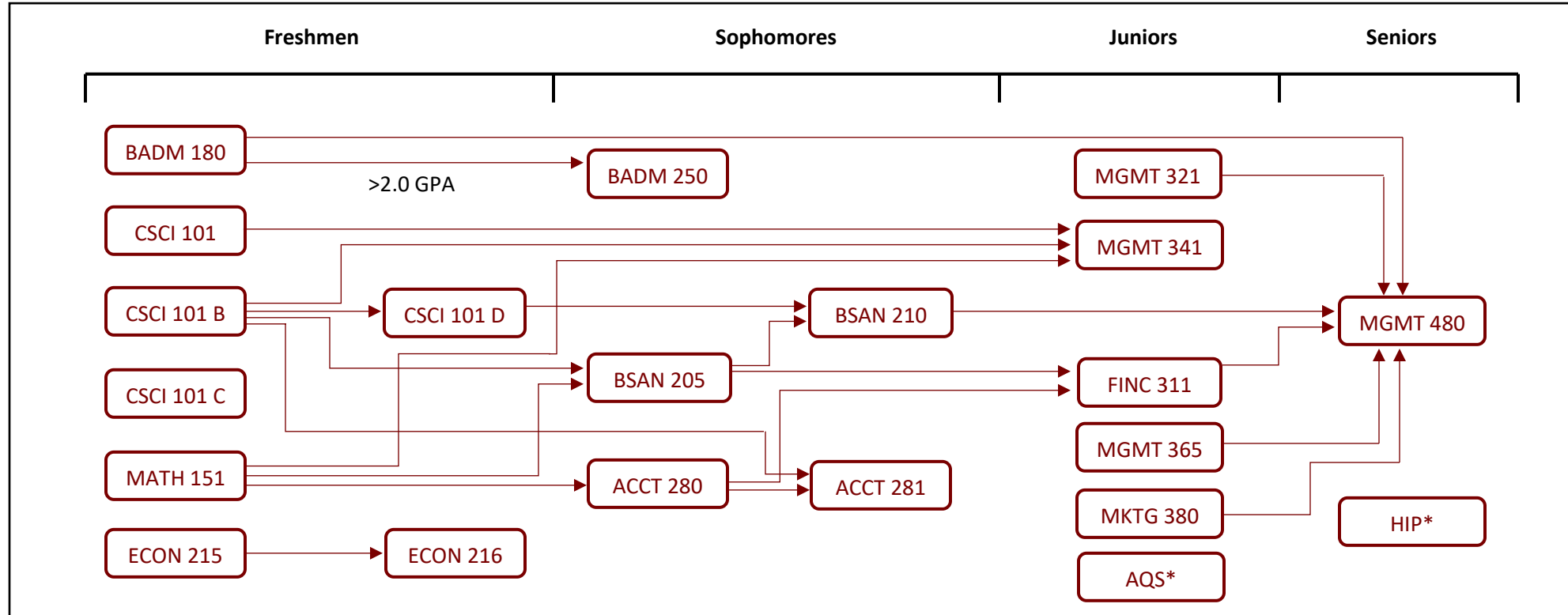

HUMAN RESOURCE MANAGEMENT - CONCENTRATION COURSES

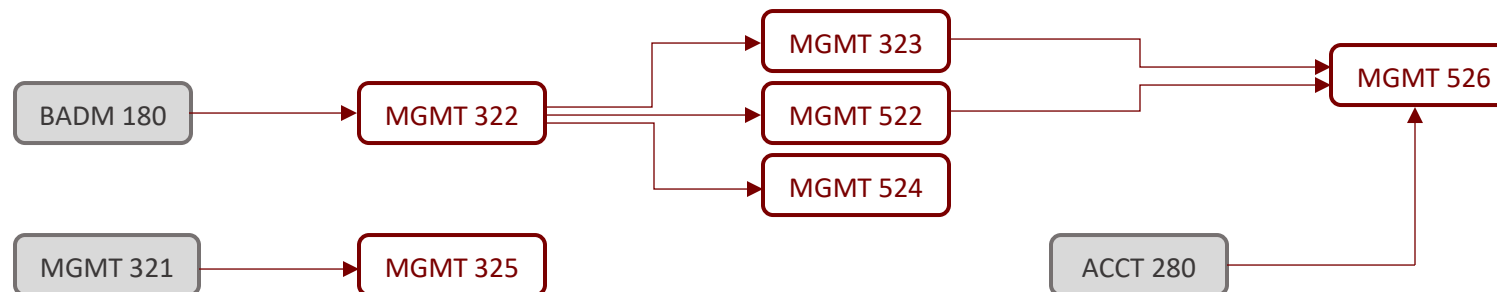

*Any class marked with a * means there are extra pre-requisites to make note of.*